

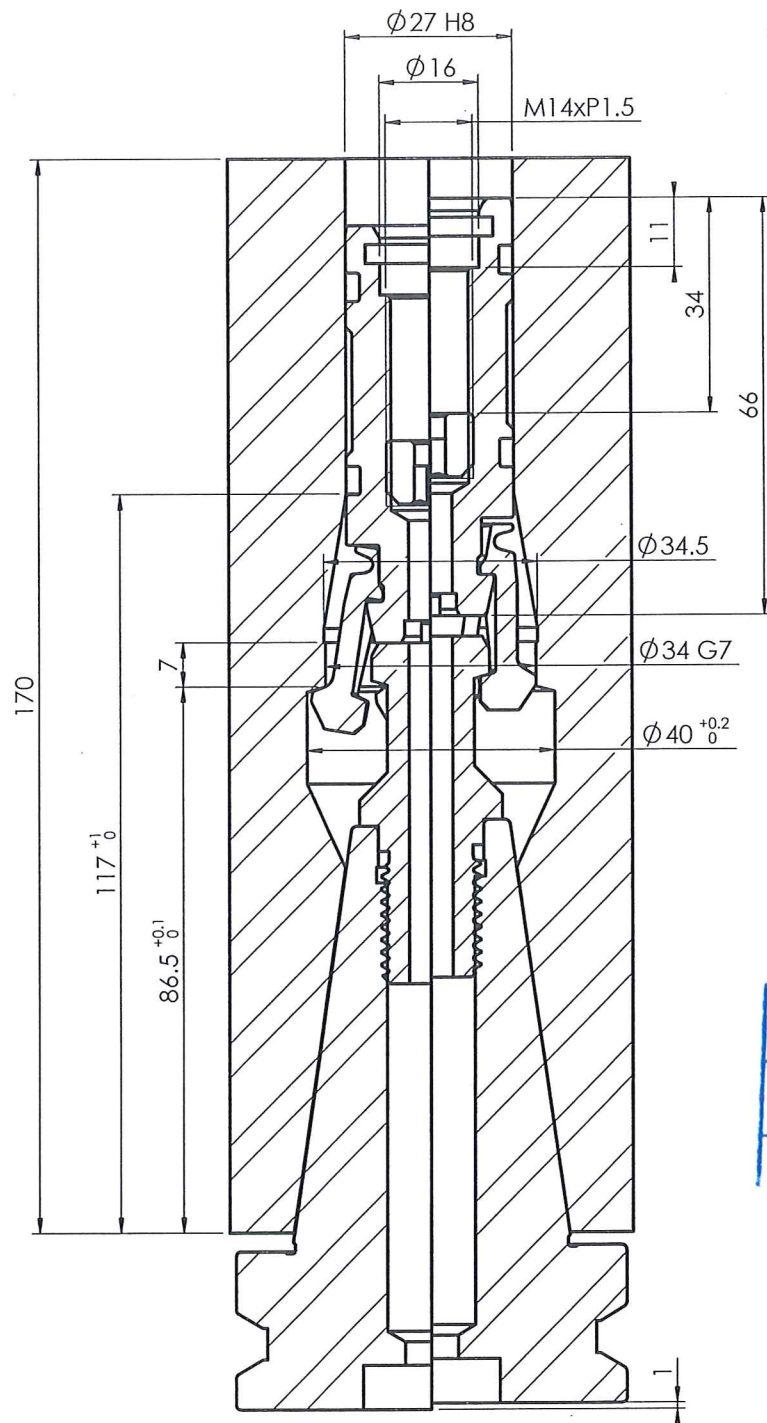

Mark	Changes	Results	Date	Engineer



CHUMPOWER  
~R&D~  
JAN 31 2019  
Issued

業務

 Hole Center Distance tolerance $\pm 0.2$	Drawn by Jun.31.2019 Roy	 CHUM POWER MACHINERY CORP.				
	Design by Jun.31.2019 Roy					
General Tolerance <math>\leq 6</math> $\pm 0.1$ <math>> 6</math> $\pm 0.2$ <math>> 30</math> $\pm 0.3$ <math>> 120</math> $\pm 0.5$ <math>> 315</math> $\pm 0.8$ <math>> 1000</math> $\pm 1.2$ Angle $\pm 0.5$	Revision Jun.31.2019 <i>Guylin</i>	Title		ROHM-DIN40		
	Approval Jun.31.2019 <i>Guylin</i>	Part No.	A4	90214 B		
	System Spindle/Gripper	Date	Name	ASM No.	ROHM-DIN40	Scale 1:1.2
	Material :	Surface Treatment :		Heat Treatment :		Unit